

PAPER : IIT-JAM 2017
PHYSICS-PH

1. **Section-A contains 30 Multiple Choice Questions (MCQ). Each question has 4 choices (a), (b), (c) and (d), for its answer, out of which ONLY ONE is correct. From Q.1 to Q.10 carries 1 Marks and Q.11 to Q.30 carries 2 Marks each.**
2. **Section-B contains 10 Multiple Select Questions (MSQ). Each question has 4 choices (a), (b), (c) and (d) for its answer, out of which ONE or MORE than ONE is/are correct. For each correct answer you will be awarded 2 marks.**
3. **Section-C contains 20 Numerical Answer Type (NAT) questions. From Q.41 to Q.50 carries 1 Mark each and Q.51 to Q.60 carries 2 Marks each. For each NAT type question, the value of answer is between 0 to 9.**
4. **In all sections, questions not attempted will result in zero mark. In Section-A (MCQ), wrong answer will result in negative marks. For all 1 mark questions, 1/3 marks will be deducted for each wrong answer. For all 2 marks questions, 2/3 marks will be deducted for each wrong answer. In Section-B (MSQ), there is no negative and no partial marking provisions. There is no negative marking in Section-C (NAT) as well.**

SECTION-A

Multiple Choice Questions (MCQ)

Q.1 – Q.10 carry one mark each.

1. Consider two, single turn, co-planar, concentric coils of radii R_1 and R_2 with $R_1 \gg R_2$. The mutual inductance between the two coils is proportional to

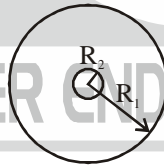

- (a) R_1 / R_2 (b) R_2 / R_1 (c) R_2^2 / R_1 (d) R_1^2 / R_2
2. Shown in the figure is a combination of logic gates. The output values at P and Q are correctly represented by which of the following?

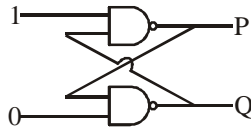

- (a) 0 0 (b) 1 1 (c) 0 1 (d) 1 0
3. Which of the following is due to inhomogeneous refractive index of earth's atmosphere?

(a) Red colour of the evening Sun (b) Blue colour of the sky

(c) Oval shape of the evening Sun (d) Large apparent size of the evening Sun
 4. If the Boolean function $Z = PQ + PQR + PQRS + PQRST + PQRSTU$, then \bar{Z} is

(a) $\bar{P}\bar{Q} + \bar{R}(\bar{S} + \bar{T} + \bar{U})$ (b) $\bar{P}\bar{Q}$

(c) $\bar{P} + \bar{Q}$ (d) $\bar{P} + \bar{Q} + \bar{R} + \bar{S} + \bar{T} + \bar{U}$

5. Consider the following circuit with two identical Si diodes. The input ac voltage waveform has the peak voltage $V_p = 2V$, as shown

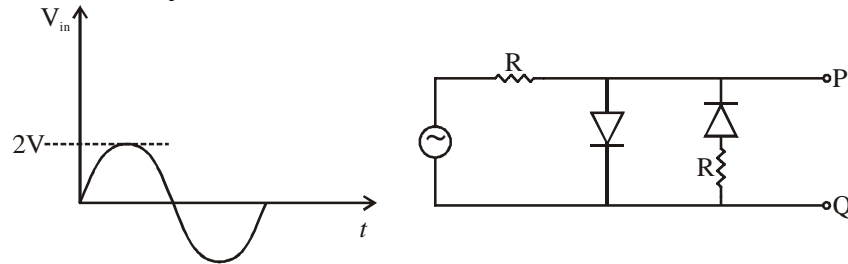

The voltage waveform across PQ will be represented by

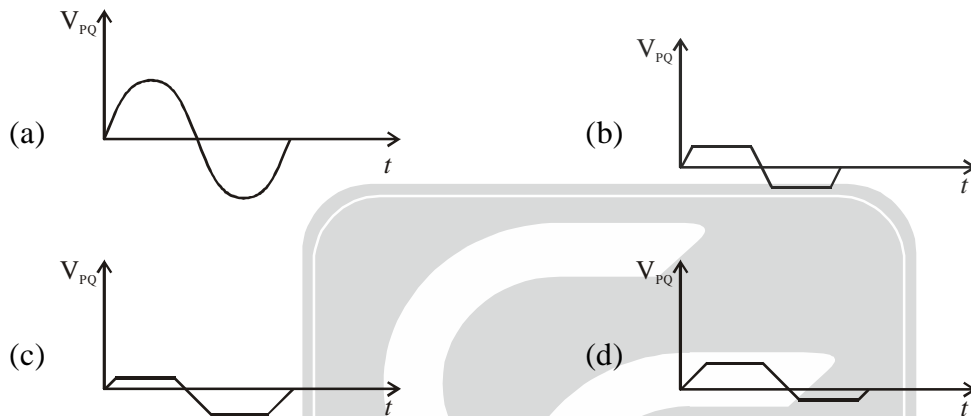

6. For the three matrices given below, which one of the choices is correct?

$$\sigma_1 = \begin{pmatrix} 0 & 1 \\ 1 & 0 \end{pmatrix} \quad \sigma_2 = \begin{pmatrix} 0 & i \\ -i & 0 \end{pmatrix} \quad \sigma_3 = \begin{pmatrix} 1 & 0 \\ 0 & -1 \end{pmatrix}$$

- (a) $\sigma_1 \sigma_2 = -i \sigma_3$ (b) $\sigma_1 \sigma_2 = i \sigma_3$
 (c) $\sigma_1 \sigma_2 + \sigma_2 \sigma_1 = I$ (d) $\sigma_3 \sigma_2 = -i \sigma_1$
7. A current $I = 10A$ flows in an infinitely long wire along the axis of a hemisphere (see figure). The value of $\int (\vec{\nabla} \times \vec{B}) \cdot d\vec{s}$ over the hemispherical surface as shown in the figure is

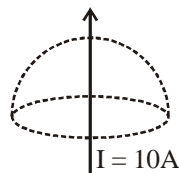

- (a) $10\mu_0$ (b) $5\mu_0$ (c) 0 (d) $7.5\mu_0$
8. A plane in a cubic lattice makes intercepts of a , $a/2$ and $2a/3$ with the three crystallographic axes, respectively. The Miller indices for this plane are
 (a) (2 4 3) (b) (3 4 2) (c) (6 3 4) (d) (1 2 3)

9. The dispersion relation for electromagnetic waves travelling in a plasma is given as $\omega^2 = c^2 k^2 + \omega_p^2$ where c and ω_p are constants. In this plasma, the group velocity is
- proportional to but not equal to the phase velocity
 - inversely proportional to the phase velocity
 - equal to the phase velocity
 - a constant
10. Which one of the following schematic curves best represents the variation of conductivity σ of a metal with temperature T ?

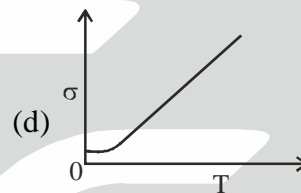
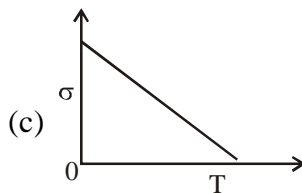
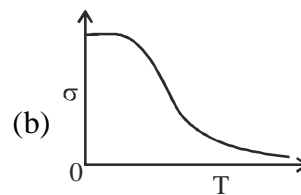
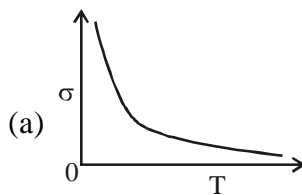

Q.11 – Q.30 carry two marks each.

11. A pendulum is made of a massless string of length L and a small bob of negligible size and mass m . It is released making an angle θ_0 ($\ll 1$ rad) from the vertical. When passing through the vertical, the string slips a bit from the pivot so that its length increases by a small amount δ ($\delta \ll L$) in negligible time. If it swings up to angle θ_1 on the other side before starting to swing back, then to a good approximation which of the following expression is correct?

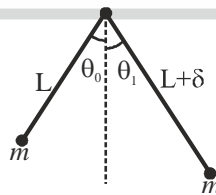

- (a) $\theta_1 = \theta_0$ (b) $\theta_1 = \theta_0 \left(1 - \frac{\delta}{2L}\right)$ (c) $\theta_1 = \theta_0 \left(1 - \frac{\delta}{L}\right)$ (d) $\theta_1 = \theta_0 \left(1 - \frac{3\delta}{2L}\right)$
12. For the Fourier series of the following function of period 2π

$$f(x) = \begin{cases} 0 & -\pi < x < 0 \\ 1 & 0 < x < \pi \end{cases}$$

the ratio (to the nearest integer) of the Fourier coefficients of the first and the third harmonic is

- (a) 1 (b) 2 (c) 3 (d) 6

13. Consider a system of N particles obeying classical statistics, each of which can have an energy 0 or E . The system is in thermal contact with a reservoir maintained at a temperature T . Let k denote the Boltzmann constant. Which one of the following statements regarding the total energy U and the heat capacity C of the system is correct?

(a) $U = \frac{NE}{1+e^{E/kT}}$ and $C = k \frac{NE}{kT} \frac{e^{E/kT}}{(1+e^{E/kT})^2}$

(b) $U = \frac{NE}{kT} \frac{E}{1+e^{E/kT}}$ and $C = k \frac{NE}{kT} \frac{e^{E/kT}}{(1+e^{-E/kT})^2}$

(c) $U = \frac{NE}{1+e^{E/kT}}$ and $C = k \frac{NE^2}{(kT)^2} \frac{e^{E/kT}}{(1+e^{E/kT})^2}$

(d) $U = \frac{NE}{1+e^{E/kT}}$ and $C = k \frac{NE^2}{(kT)^2} \frac{e^{E/kT}}{(1+e^{E/kT})^2}$

14. Consider an inertial frame S' moving at speed $c/2$ away from another inertial frame S along the common $x-x'$ axis, where c is the speed of light. As observed from S' , a particle is moving with speed $c/2$ in the y' direction, as shown in the figure. The speed of the particle as seen from S is:

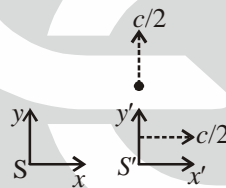

- (a) $c/\sqrt{2}$ (b) $c/2$ (c) $\sqrt{7}c/4$ (d) $\sqrt{3}c/5$
15. An n-p-n transistor is connected in a circuit as shown in the figure. If $I_C = 1\text{mA}$, $\beta = 50$, $V_{BE} = 0.7\text{V}$, and the current through R_2 is $10I_B$, where I_B is the base current. Then the ratio R_1/R_2 is

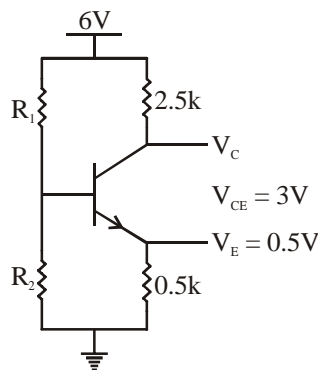

- (a) 0.375 (b) 0.25 (c) 0.5 (d) 0.275

16. KCl has the NaCl type structure which is fcc with two-atom basis, one at $(0, 0, 0)$ and the other at $\left(\frac{1}{2}, \frac{1}{2}, \frac{1}{2}\right)$. Assume that the atomic form factors of K^+ and Cl^- are identical. In an x -ray diffraction experiment on KCl, which of the following $(h k l)$ peaks will be observed?
 (a) $(1 0 0)$ (b) $(1 1 0)$ (c) $(1 1 1)$ (d) $(2 0 0)$
17. The electric field of an electromagnetic wave is given by $\vec{E} = (2\hat{k} - 3\hat{j}) \times 10^{-3} \sin[10^7(x + 2y + 3z - \beta t)]$. The value of β is (c is the speed of light)
 (a) $\sqrt{14}c$ (b) $\sqrt{12}c$ (c) $\sqrt{10}c$ (d) $\sqrt{7}c$
18. A white dwarf star has volume V and contains N electrons so that the density of electrons is $n = \frac{N}{V}$. Taking the temperature of the star to be 0 K, the average energy per electron in the star is $\epsilon_0 = \frac{3\hbar^2}{10m} (3\pi^2 n)^{2/3}$, where m is the mass of the electron. The electronic pressure in the star is
 (a) $n\epsilon_0$ (b) $2\pi\epsilon_0$ (c) $\frac{1}{3}n\epsilon_0$ (d) $\frac{2}{3}n\epsilon_0$
19. Consider Rydberg (hydrogen-like) atoms in a highly excited state with n around 300. The wavelength of radiation coming out of these atoms for transitions to the adjacent states lies in the range:
 (a) Gamma rays ($\lambda \sim \text{pm}$) (b) UV ($\lambda \sim \text{nm}$)
 (c) Infrared ($\lambda \sim \mu\text{m}$) (d) RF ($\lambda \sim \text{m}$)
20. The integral of the vector $\vec{A}(\rho, \varphi, z) = \frac{40}{\rho} \cos \varphi \hat{\rho}$ (standard notation for cylindrical coordinates is used) over the volume of a cylinder of height L and radius R_0 is
 (a) $20\pi R_0 L (\hat{i} + \hat{j})$ (b) 0 (c) $40\pi R_0 L \hat{j}$ (d) $40\pi R_0 L \hat{i}$
21. To demonstrate Bernoulli's principle, an instructor arrange two circular horizontal plates of radii b each with distance d ($d \ll b$) between them (see figure). The upper plate has a hole of radius a in the middle. On blowing air at a speed v_0 through the hole so that the flow rate of air is $\pi a^2 v_0$ it is seen that the lower plate does not fall. If the density of air is ρ , the upward force on the lower plate is well approximated by the formula (assume that the region with $r < a$ does not contribute to the upward force and the speed of air at the edges is negligible)

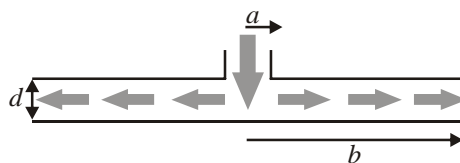

- (a) $\frac{\pi \rho v_0^2 a^4}{4d^2} \ln\left(\frac{b}{a}\right)$ (b) $\frac{\pi \rho v_0^2 a^2 b^2}{4d^2} \ln\left(\frac{b}{a}\right)$ (c) $\frac{\pi \rho v_0^2 d^2}{2ab} \ln\left(\frac{b}{a}\right)$ (d) $\frac{2\pi \rho v_0^2 a^4}{d^2} \ln\left(\frac{b}{a}\right)$

22. Consider two identical, finite, isolated systems of constant heat capacity C at temperature T_1 and T_2 , ($T_1 > T_2$). An engine works between them until their temperatures become equal. Taking into account that the work performed by the engine will be maximum ($= W_{\max}$) if the process is reversible (equivalently, the entropy change of the entire system is zero), the value of W_{\max} is

- (a) $C(T_1 - T_2)$ (b) $C(T_1 - T_2)/2$ (c) $C(T_1 + T_2 - \sqrt{T_1 T_2})$ (d) $C(\sqrt{T_1} - \sqrt{T_2})^2$

23. Unpolarized light is incident on a combination of a polarizer, a $\lambda/2$ plate and a $\lambda/4$ plate kept one after the other. What will be the output polarization for the following configurations? Configuration 1: Axes of the polarizer, the $\lambda/2$ plate and the $\lambda/4$ plate are all parallel to each other.

Configuration 2: The $\lambda/2$ plate is rotated by 45° with respect to configuration 1

Configuration 3: The $\lambda/4$ plate is rotated by 45° with respect to configuration 1

- (a) Linear for configuration 1, linear for configuration 2, circular for configuration 3
 (b) Linear for configuration 1, circular for configuration 2, circular for configuration 3
 (c) Circular for configuration 1, circular for configuration 2, circular for configuration 3
 (d) Circular for configuration 1, linear for configuration 2, circular for configuration 3

24. In the radiation emitted by a black body, the ratio of the spectral densities at frequencies 2ν and ν will vary with ν as

- (a) $|e^{h\nu/k_B T} - 1|^{-1}$ (b) $|e^{h\nu/k_B T} + 1|^{-1}$ (c) $|e^{h\nu/k_B T} - 1|$ (d) $|e^{h\nu/k_B T} + 1|$

25. Which one of the following graphs represents the derivative $f'(x) = \frac{df}{dx}$ of the function

$f(x) = \frac{1}{1+x^2}$ most closely (graphs are schematic and not drawn to scale)?

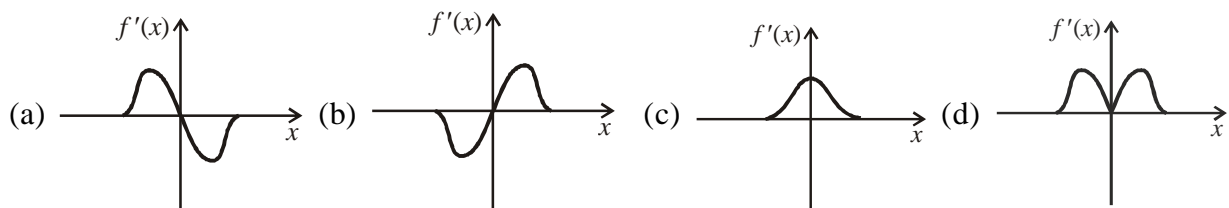

26. Consider a thin long insulator coated conducting wire carrying current I . It is now wound once around an insulating thin disc of radius R to bring the wire back on the same side, as shown in the figure. The magnetic field at the centre of the disc is equal to:

- (a) $\frac{\mu_0 I}{2R}$ (b) $\frac{\mu_0 I}{4R} \left[3 + \frac{2}{\pi} \right]$
 (c) $\frac{\mu_0 I}{4R} \left[1 + \frac{2}{\pi} \right]$ (d) $\frac{\mu_0 I}{2R} \left[1 + \frac{1}{\pi} \right]$

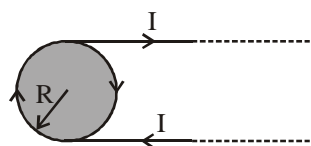

27. A rectangular loop of dimension L and width w moves with a constant velocity v away from an infinitely long straight wire carrying a current I in the plane of the loop as shown in the figure below. Let R be the resistance of the loop. What is the current in the loop at the instant the near-side is at a distance r from the wire?

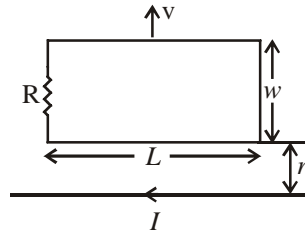

- (a) $\frac{\mu_0 I L}{2\pi R} \frac{wv}{r[r+2w]}$ (b) $\frac{\mu_0 I L}{2\pi R} \frac{wv}{r[2r+w]}$ (c) $\frac{\mu_0 I L}{2\pi R} \frac{wv}{r[r+w]}$ (d) $\frac{\mu_0 I L}{2\pi R} \frac{wv}{2r[r+w]}$
28. A uniform rigid meter-scale is held horizontally with one of its end at the edge of a table and the other supported by hand. Some coins of negligible mass are kept on the meter scale as shown in the figure.

As the hand supporting the scale is removed, the scale starts rotating about its edge on the table and the coins start moving. If a photograph of the rotating scale is taken soon after, it will look closest to



29. Consider two coherent point sources (S_1 and S_2) separated by a small distance along a vertical line and two screen P_1 and P_2 placed as shown in Figure. Which one of the choices represents the shapes of the interference fringes at the central regions on the screens?
- (a) Circular on P_1 and straight lines on P_2
 (b) Circular on P_1 and circular on P_2
 (c) Straight lines on P_1 and straight lines on P_2
 (d) Straight lines on P_1 and circular on P_2

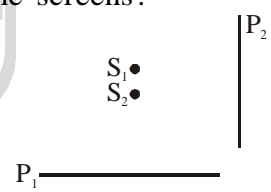

30. Consider a uniform thin circular disk of radius R and mass M . A concentric square of side $R/2$ is cut out from the disk (see figure). What is the moment of inertia of the resultant disk about an axis passing through the centre of the disk and perpendicular to it?

(a) $I = \frac{MR^2}{4} \left[1 - \frac{1}{48\pi} \right]$ (b) $I = \frac{MR^2}{2} \left[1 - \frac{1}{48\pi} \right]$
 (c) $I = \frac{MR^2}{4} \left[1 - \frac{1}{24\pi} \right]$ (d) $I = \frac{MR^2}{2} \left[1 - \frac{1}{24\pi} \right]$

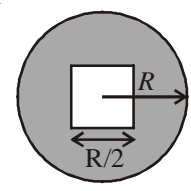

SECTION-B

Multiple Select Questions (MSQ)

Q.31 – Q.40 carry TWO marks each.

31. Consider a one-dimensional harmonic oscillator of angular frequency ω . If 5 identical particles occupy the energy levels of this oscillator at zero temperature, which of the following statement (s) about their ground state energy E_0 is (are) correct?
- (a) If the particle are electrons, $E_0 = \frac{13}{2} \hbar\omega$
- (b) If the particles are protons, $E_0 = \frac{25}{2} \hbar\omega$
- (c) If the particles are spin-less fermions, $E_0 = \frac{25}{2} \hbar\omega$
- (d) If the particles are bosons, $E_0 = \frac{5}{2} \hbar\omega$
32. The linear mass density of a rod of length l , varies from one end to the other as $\lambda_0 \left(1 + \frac{x^2}{L^2}\right)$, where x is the distance from one end with tensions T_1 and T_2 in them (see figure), and λ_0 is a constant. The rod is suspended from a ceiling by two massless strings. Then, which of the following statement (s) is (are) correct?
- (a) The mass of the rod is $\frac{2\lambda_0 L}{3}$
- (b) The center of gravity of the rod is located at $x = \frac{9L}{16}$
- (c) The tension T_1 in the left string is $\frac{7\lambda_0 Lg}{12}$
- (d) The tension T_2 in the right string is $\frac{3\lambda_0 Lg}{2}$
33. For an atomic nucleus with atomic number Z and mass number A , which of the following is (are) correct?
- (a) Nuclear matter and nuclear charge are distributed identically in the nuclear volume
- (b) Nuclei with $Z > 83$ and $A > 209$ emit α -radiation
- (c) The surface contribution to the binding energy is proportional to $A^{2/3}$
- (d) β -decay occurs when the proton to neutron ratio is large, but not when it is small
34. A dielectric sphere of radius R has constant polarization $\vec{P} = P_0 \hat{z}$ so that the field inside the sphere is $\vec{E}_{in} = -\frac{P_0}{3\epsilon_0} \hat{z}$. Then, which of the following is (are) correct?
- (a) The bound surface charge density is $P_0 \cos \theta$
- (b) The electric field at a distance r on the z -axis varies as $\frac{1}{r^2}$ for $r \gg R$
- (c) The electric potential at a distance $2R$ on the z -axis is $\frac{P_0 R}{12\epsilon_0}$
- (d) The electric field outside is equivalent to that of a dipole at the origin



35. A particle of mass m fixed in space is observed from a frame rotating about its z-axis with angular speed ω . The particle is in the frame's xy plane at a distance R from its origin. If the Coriolis and centrifugal forces on the particle are \vec{F}_{COR} and \vec{F}_{CFG} , respectively, then (all the symbols have their standard meaning and refer to the rotating frame)
- (a) $\vec{F}_{COR} + \vec{F}_{CFG} = 0$ (b) $\vec{F}_{COR} + \vec{F}_{CFG} = -m\omega^2 R\hat{r}$
(c) $\vec{F}_{COR} = -2m\omega^2 R\hat{r}$ (d) $\vec{F}_{CFG} = -m\omega^2 R\hat{r}$
36. Consider a circular parallel plate capacitor of radius R with separation d between the plates ($d \ll R$). The plates are placed symmetrically about the origin. If a sinusoidal voltage $V = V_0 \sin \omega t$ is applied between the plates, which of the following statement (s) is (are) true?
- (a) The maximum value of the Poynting vector at $r = R$ is $\frac{V_0^2 \epsilon_0 \omega R}{4d^2}$
(b) The average energy per cycle flowing out of the capacitor is zero
(c) The magnetic field inside the capacitor is constant
(d) The magnetic field lines inside the capacitor are circular with the curl being independent of r
37. An isolated box is divided into two equal compartments by a partition (see figure). One compartment contains a van der Waals gas while the other compartment is empty. The partition between the two compartments is now removed. After the gas has filled the entire box and equilibrium has been achieved, which of the following statement (s) is (are) correct?
- (a) Internal energy of the gas has not changed
(b) Internal energy of the gas has decreased
(c) Temperature of the gas has increased
(d) Temperature of the gas has decreased
- 
38. A photon of frequency ν strikes an electron of mass m initially at rest. After scattering at an angle ϕ , the photon loses half of its energy. If the electron recoils at an angle θ , which of the following is (are) true?
- (a) $\cos \phi = \left(1 - \frac{mc^2}{h\nu}\right)$
(b) $\sin \theta = \left(1 - \frac{mc^2}{h\nu}\right)$
(c) The ratio of the magnitudes of momenta of the recoiled electron and scattered photon is $\frac{\sin \phi}{\sin \theta}$
(d) Change in photon wavelength is $\frac{h}{mc}(1 - 2 \cos \phi)$

39. For a point dipole of dipole moment $\vec{p} = p\hat{z}$ located at the origin, which of the following is (are) **correct**?
- (a) The electric field at $(0, b, 0)$ is zero
- (b) The work done in moving a charge q from $(0, b, 0)$ to $(0, 0, b)$ is $\frac{qp}{4\pi\epsilon_0 b^2}$
- (c) The electrostatic potential at $(b, 0, 0)$ is zero
- (d) If a charge q is kept at $(0, 0, b)$ it will exert a force of magnitude $\frac{qp}{4\pi\epsilon_0 b^2}$ on the dipole
40. An object of mass m with non-zero angular momentum ℓ is moving under the influence of gravitational force of a much larger mass (ignore drag). Which of the following statement (s) is (are) correct?
- (a) If the total energy of the system is negative, then the orbit is always circular
- (b) The motion of m always occurs in a two dimensional plane
- (c) If the total energy of the system is 0, then the orbit is a parabola
- (d) If the area of the particle's bound orbit is S , then its time period is $2mS/\ell$

SECTION-C

Numerical Answer Type (NAT)

Q.41 – Q.50 carry ONE mark each.

41. Consider a Carnot engine operating between temperatures of 600K and 400K. The engine performs 1000J of work per cycle. The heat (in Joules) extracted per cycle from the high temperature reservoir is _____
(Specify your answer to two digits after the decimal point)
42. In a coaxial cable, the radius of the inner conductor is 2 mm and that of the outer one is 5 mm. The inner conductor is at a potential of 10V, while the outer conductor is grounded. The value of the potential at a distance of 3.5 mm from the axis is _____
(Specify your answer in volts to two digits after the decimal point)

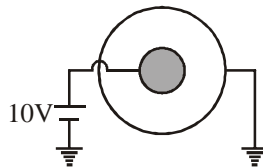

43. An anti-reflection film coating of thickness $0.1\mu\text{m}$ is to be deposited on a glass plate for normal incidence of light of wavelength $0.5\mu\text{m}$. What should be the refractive index of the film? _____
(Specify your answer to two digits after the decimal point)
44. An intrinsic semiconductor of band gap 1.25 eV has an electron concentration 10^{10} cm^{-3} at 300K. Assume that its band gap is independent of the temperature and that the electron concentration depends only exponentially on the temperature. If the electron concentration at 200K is $Y \times 10^N\text{ cm}^{-3}$ ($1 < Y < 10$, $N = \text{integer}$), then the value of N is _____

45. Intensity versus distance curve for a double slit diffraction experiment is shown in the figure below. If the width of each of the slits is $0.7\mu\text{m}$ what is the separation between the two slits in micrometers? _____
 (Specify your answer to two digits after the decimal point)

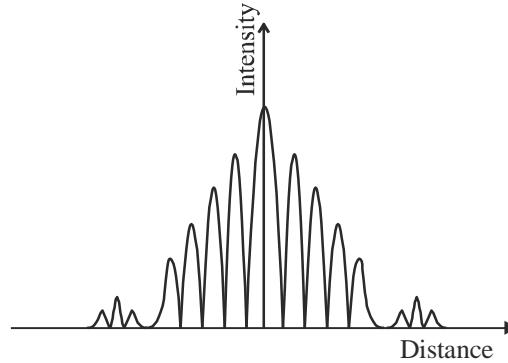

46. Sand falls on a conveyor belt at the rate of 1.5 kg/s . If the belt is moving with a constant speed of 7 m/s , the power needed to keep the conveyor belt running is _____
 (Specify your answer in Watts to two digits after the decimal point)
47. The wave number of an electromagnetic wave incident on a metal surface is $(20\pi + 750i)m^{-1}$ inside the metal, where $i = \sqrt{-1}$. The skin depth of the wave in the metal is _____
 (Specify your answer in mm to two digits after the decimal point)
48. Unpolarized light of intensity I_0 passes through a polarizer P_1 . The light coming out of the polarizer falls on a quarter-wave plate with its optical axis at 45° with respect to the polarization axis of P_1 and then passes through another polarizer P_2 with its polarization axis perpendicular to that of P_1 . The intensity of the light coming out of P_2 is I . The ratio I_0/I is _____
 (Specify your answer to two digits after the decimal point)
49. A particle of mass m is placed in a three-dimensional cubic box of side a . What is the degeneracy of its energy level with energy $14\left(\frac{\hbar^2\pi^2}{2ma^2}\right)$? _____
 (Express your answer as an integer)
50. A particle of unit mass is moving in a one-dimensional potential $V(x) = x^2 - x^4$. The minimum mechanical energy (in the same units as $V(x)$) above which the motion of the particle cannot be bounded for any given initial condition is _____
 (Specify your answer to two digits after the decimal point)

Q.51 – Q.60 carry TWO marks each.

51. The volume integral of the function $f(r, \theta, \phi) = r^2 \cos \theta$ over the region $(0 \leq r \leq 2, 0 \leq \theta \leq \pi/3$ and $0 \leq \phi \leq 2\pi)$ is _____
(Specify your answer to two digits after the decimal point)
52. Consider two particles moving along the x -axis. In terms of their coordinates x_1 and x_2 , their velocities are given as $\frac{dx_1}{dt} = x_2 - x_1$ and $\frac{dx_2}{dt} = x_1 - x_2$, respectively. When they start moving from their initial locations of $x_1(0) = 1$ and $x_2(0) = -1$, the time dependence of both x_1 and x_2 contains a term of the form e^{at} , where a is a constant. The value of a (an integer) is _____
53. In planar polar co-ordinate, an object's position at time t is given as $(r, \theta) = (e^t m, \sqrt{8t} \text{ rad})$. The magnitude of its acceleration in m/s^2 at $t = 0$ (to the nearest integer) is _____
54. At $t = 0$, a particle of mass m having velocity v_0 starts moving through a liquid kept in a horizontal tube and experience a drag force $\left(F_d = -k \frac{dx}{dt}\right)$. It covers a distance L before coming to rest. If the times taken to cover the distances $L/2$ and $L/4$ are t_2 and t_4 respectively, then the ratio t_2/t_4 (ignoring gravity) is _____
(Specify your answer to two digits after the decimal point)
55. A sphere of radius R has a uniform charge density ρ . A sphere of smaller radius $\frac{R}{2}$ is cut out from the original sphere, as shown in the figure below. The centre of the cut out sphere lies at $z = \frac{R}{2}$. After the smaller sphere has been cut out, the magnitude of the electric field at $z = -\frac{R}{2}$ is $\frac{\rho R}{n \epsilon_0}$. The value of the integer n is _____

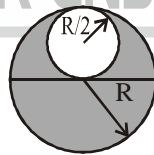

56. An OPAMP is connected in a circuit with a Zener diode as shown in the figure. The value of resistance R in $k\Omega$ for obtaining a regulated output $V_0 = 9\text{V}$ is _____
(Specify your answer to two digits after the decimal point)

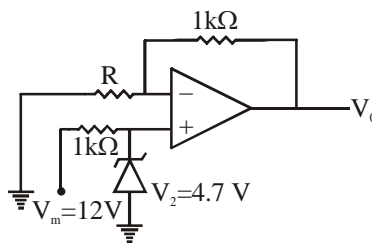

57. Starting with the equation $TdS = dU + pdV$ and using the appropriate Maxwell's relation along with the expression for heat capacity C_p (see useful information), the derivative $\left(\frac{\partial p}{\partial T}\right)_S$ for a substance can be expressed in terms of its specific heat c_p , density ρ , coefficient of volume expansion β and temperature T . For ice, $c_p = 2010$ J/kg-K, $\rho = 10^3$ kg/m³ and $\beta = 1.6 \times 10^{-4}/^\circ\text{K}$. If the value of $\left(\frac{\partial p}{\partial T}\right)_S$ at 270 K is $N \times 10^7$ Pa/K, then the value of N is _____
(Specify your answer to two digits after the decimal point)
58. For a proton to capture an electron to form a neutron and a neutrino (assumed massless), the electron must have some minimum energy. For such an electron the de-Broglie wavelength in picometers is _____
(Specify your answer to two digits after the decimal point)
59. Consider the differential equation $y'' + 2y' + y = 0$. If $y(0) = 0$ and $y'(0) = 1$, then the value of $y(2)$ is _____
(Specify your answer to two digits after the decimal point)
60. In an electron microscope, electrons are accelerated through a potential difference of 200kV. What is the best possible resolution of the microscope? _____
(Specify your answer in picometers to two digits after the decimal point)

